

FREE ECONOMIC ZONE  
 **CAAN**  
INDUSTRIAL PARK

August 2017  
Republic of Moldova

# CONCEPT

## CONCEPT

Dear partners,

You will find in this presentation the main advantages and opportunities that the Industrial Park and Free Economic Zone CAAN can offer for the revival of your business.

CAAN is a private company, founded on the assets of the company "Masfrigomplect" located in Straseni city, at 25 km from Chisinau, the capital of Republic of Moldova. In 2012, a Free Economic Zone was instituted on 12 ha of the territory of Industrial Park CAAN, giving access to tax incentives and legislation advantages.

Today, CAAN is offering you a unique combination of Fiscal and Real-Estate benefits, amplified by a customer oriented private ownership management.

Thank you for reviewing this presentation.

I will be pleased to answer to your questions related to our future cooperation.

Stimati parteneri,

Veti gasi in aceasta prezentare principalele avantaje si oportunitati pe care parcul industrial "CAAN" le poate oferi pentru relansarea afacerii Dvs pe piata internationala.

Parcul Industrial "CAAN" este o companie privata, fondata pe baza activelor societatii "Maşfrigomplect", amplasata in orasul Straseni. In anul 2012, pe o suprafata de 12 ha a societatii SA "CAAN" este instituita subzona nr 4 a Zonei Economice Libere "Balti", oferind rezidentilor accesul la facilitati fiscale si legislative.

Actualemente, CAAN pune la dispozitia rezidentilor sai spatii pentru productie si depozitare de diferite configuratii, oficii si teren pentru constructii conectate la toate retelele ingineresti.

Parcul Industrial "CAAN" va ofera o combinatie unica de avantaje fiscale, legislative si logistice care vor asigura succesul afacerii Dvs.

Va multumesc pentru examinarea acestei prezentari. Voi fi bucuros sa raspund la intrebarile Dvs legate de viitoarea noastra cooperare.

Best regards  
Cu stimă,

Constantin CHITANU  
Development Manager



# Key Facts

## FACTORI CHEIE

# 12

hectares of free economic zone land

*hectare de zona economica libera*

# 56300

sq meters - total area of the buildings within fez

*metri patrati suprafata totala a cladirilor din cadrul zel*

# 12

registered residents

*rezidenti inregistrati*

# 6

investors from 6 countries (IT, NL, SE, MD, BE, CN)

*investitori din 6 tari*

- ▶ Private shareholder with flexible rent policy

*Societate cu capital privat, cu o politica flexibila de reduceri pentru chirie*

- ▶ Full access to tax incentives and convenient (near Chisinau) location

*Acces la facilitati fiscale si logistice (oferite de proximitatea de Chisinau)*

- ▶ Start-up Legal and Business Plan Assistance

*Asistenta juridica si manageriala pentru demararea afacerii*

- ▶ Sewerage, water, gas and 10 MW/h electricity on site

*Sisteme de apeduct, canalizare, gaz si electricitate (10 MW/h) disponibile*

- ▶ Custom and broker offices on site

*Birou vamal si broker vamal disponibili pe teritoriu pentru toate formalitatile de import/export*

- ▶ 35000 sq meters - size of Production Facility nr 1 (allowing the implementation of massive industrial projects)

*35000 metri patrati disponibili in cadrul Blocului de Productie nr 1 (permite implementarea unor proiecte ample)*

- ▶ Tenant improvement Allowance

*Facilitati aditionale*

## Location

### Locatia

V Crasescu 1 str., MD-3701, Straseni city, only 22 km from Chisinau and with connection to European road E58 (Chisinau-Ungheni-Sculeni-border with RO), highway M14 (Brest-Briceni-Chisinau-border with UA), European road E581 (Chisinau-Leuseni – border with RO).

*Strada V. Crasescu, 1, MD- 3701, orasul Straseni, la 20 km de Chisinau, cu conectiuni rapide la Drumul European E58 (Chisinau-Ungheni-Sculeni-Frontiera cu Romania), Drumul International M14 (Brest-Briceni-Chisinau-Odessa), Drumul European E581 (Chisinau-Leuseni-Frontiera cu Romania).*

# "CAAN" Industrial Park and Free Economic Zone (FEZ) Location

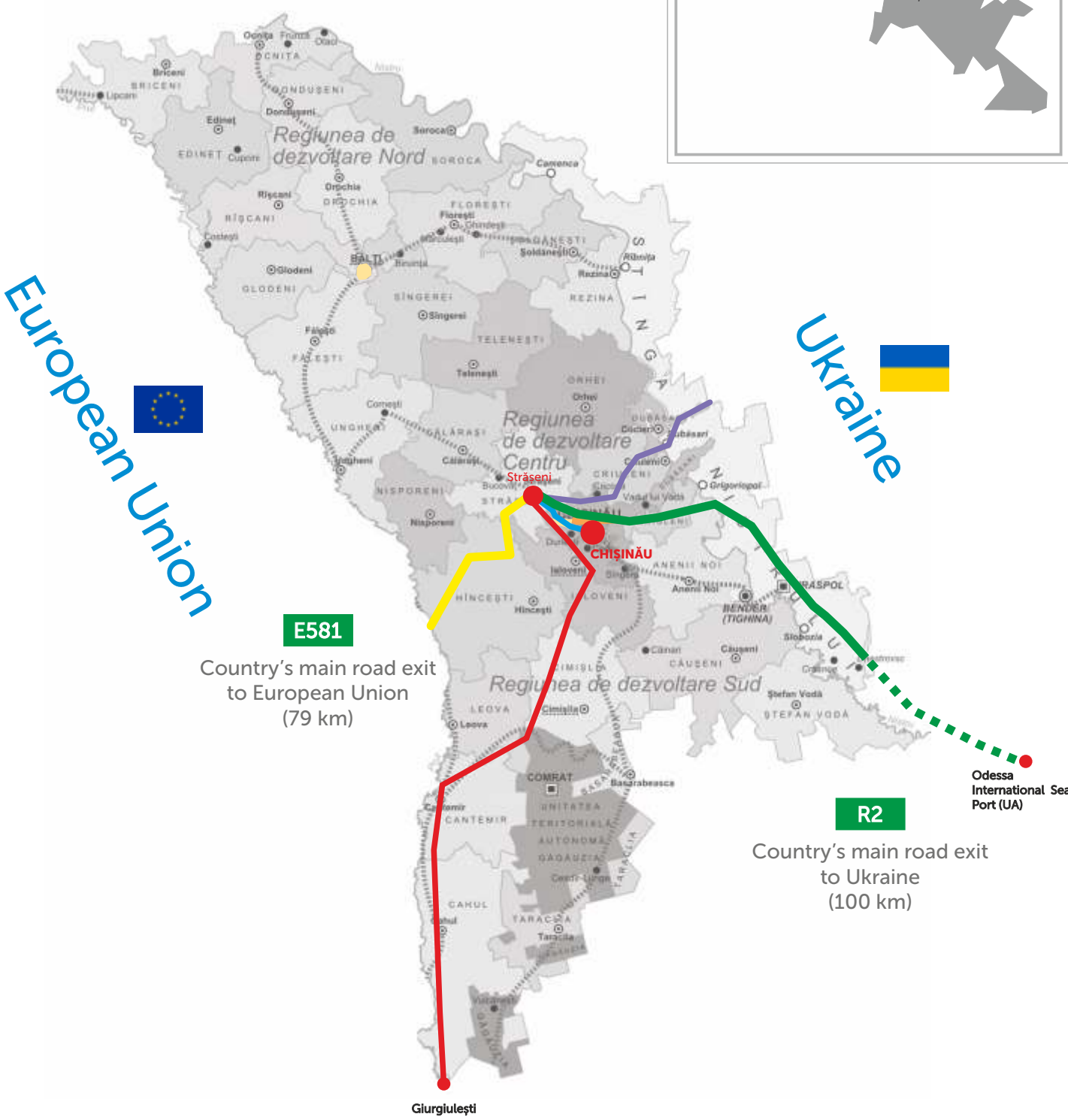
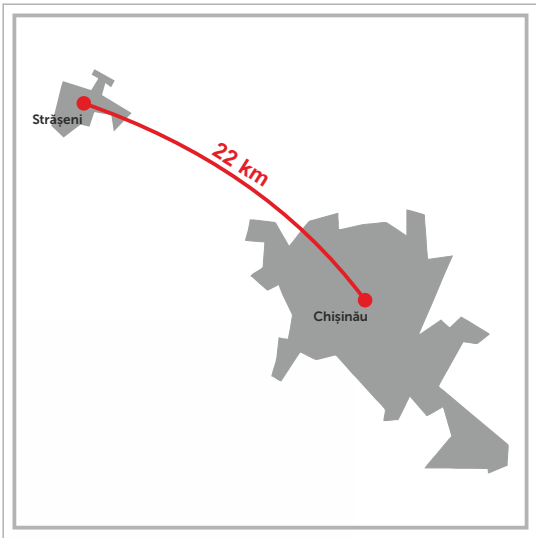

Chisinau  
 Border with EU  
 Border with UA  
 Giurgulesti International Free Port (MD)  
 Odessa Commercial Sea Port (UA)

- 22 km (25 min)
- 79 km (1h5min)
- 79 km (1h5min)
- 239 km (3h35)
- - - - - 221 km (3h17min)

# "CAAN" Industrial Park and Free Economic Zone (FEZ) Site Plan

Strășeni

E58

Parking area

Lorry Entrance and  
Customs Checkpoint

Personnel  
Entrance

Production Facility No 3

Production Facility No 2

Administrative Building

Canteen

Production Facility No 1

Production Facility No 4

- CAAN Free Economic Zone Facilities  
(GLA = 56'300 sq m)
- CAAN Industrial Park Facilities  
(GLA = 18'100 sq m)
- Greenfield  
(GLA = 20 ha)

# OUR OFFERINGS OF PRODUCTION PREMISES INCLUDE 3 TYPES OF RENOVATED AND TO BE RENOVATED BUILDINGS

VĂ OFERIM SPAȚII CU ACESTE CONFIGURAȚII

Type A

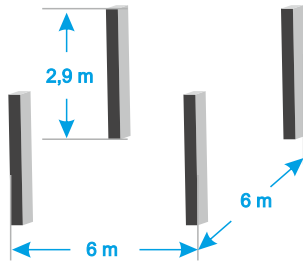

MAX FLOOR LOAD  
Sarcina maxima pentru podea

**1** t /sqm

Type B

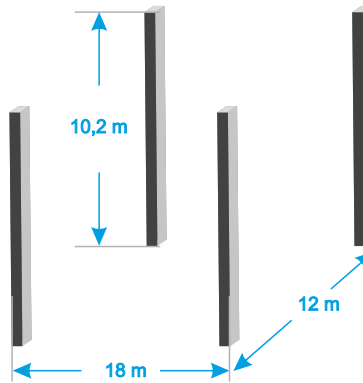

MAX FLOOR LOAD  
Sarcina maxima pentru podea

up to **5** t /sqm

Type C

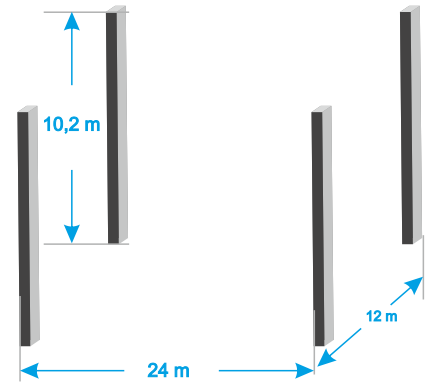

MAX FLOOR LOAD  
Sarcina maxima pentru podea

up to **5** t /sqm

## BUILDING DISTRIBUTION PER FEZ DISTRIBUTIA IN CADRUL ZEL

**10 900** sqm

**10 800** sqm

**35300** sqm

## BUILDING DISTRIBUTION PER INDUSTRIAL PARK DISTRIBUTIA IN CADRUL PARCULUI INDUSTRIAL

**7350** sqm

**4850** sqm

OUR OFFERING OF GREENFIELD OPPORTUNITIES INCLUDE

**20** ha

OF CONSTRUCTION AUTHORISED LAND

*Inclusiv 20 hectare de teren de tip Greenfield cu autorizatie de constructie*

ALL REAL-ESTATE OFFERINGS INCLUDE ON-SITE AVAILABILITY OF  
Toate rețelele ingineresti sunt conectate și funcționale



HIGHT VOLTAGE



GAS



WATER



SEWERAGE

# WE GIVE YOU ACCESS TO STRONG AND REGIONALLY COMPETITIVE CORPORATE INCOME TAX (CIT) AND EMPLOYMENT ADVANTAGES

Va oferim acces la un impozit pe venit competitiv, precum și avantajele unei forțe de muncă ieftină

## CIT in MOLDOVA

FROM EXPORT  
FROM OTHER

CIT NON FEZ MD REZIDENT

12%



CIT in Romania



CIT in Serbia

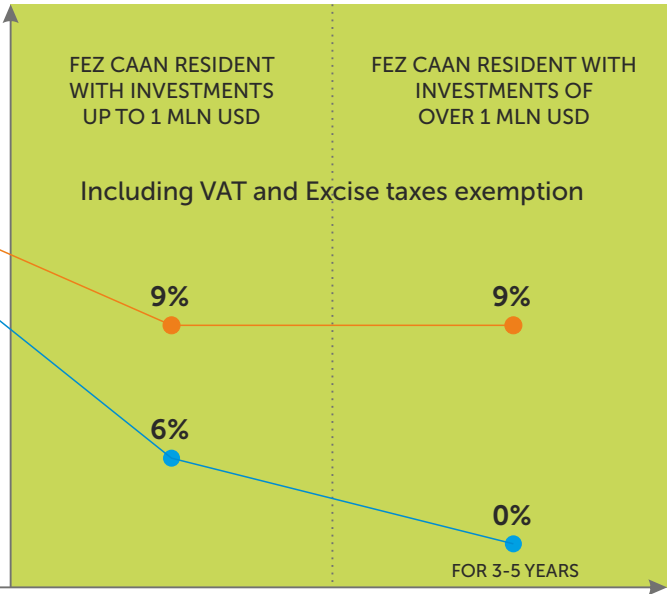

### Monthly Minimum Gross Wage, end of 2016 Salariul Minim Brut, sfirsit de 2016



### Monthly Average Gross Wage, for 2016 Salariul Mediu Brut pe economie



Monthly Average Gross Wage in Straseni District **185 euro**

Straseni average effective unemployment rate **20%**

## Education INFRASTRUCTURE

(within 40km from CAAN)



38

Universities

Universitati si Academii



17

Colleges, Professional Schools and Centers of Excellence

Colegii, Scolii Profesionale si Centre de Excelenta

## 60 000 QUALIFIED AND UNQUALIFIED PEOPLE WORKFORCE AVAILABLE, WITHIN 15KM OF CAAN

Forța de muncă calificată și ne calificată pe o rază de 15km de CAAN

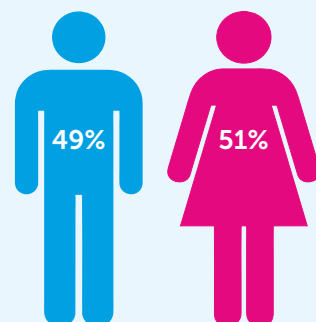
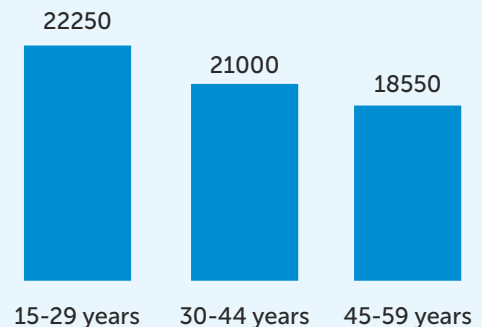

# WE PUT YOUR BUSINESS IN A SAFE LEGAL AND EDUCATIONAL ENVIRONMENT

*Veti activa într-un cadru legislativ sigur, cu acces la instrumente de calificare a personalului*



---

## FIRST IN MOLDOVA Engineering College with Dual Education System (up to 75 apprentices per shift) ON SITE

*Primul in Moldova  
colegiu cu sistem de  
invatamint de tip dual,  
amplasat pe teritoriul CAAN*



---

## YOUR INVESTMENT IS UNDER GOVERNMENT WARRANTY

*Investitiile sunt garantate  
de catre STAT amplasat  
pe teritoriul CAAN*



---

## YOUR ACTIVITY'S LEGAL FRAMEWORK IS EXEMPTED FROM AMENDMENTS (UNLESS YOU DECIDE OTHERWISE)

*Inghetati cadrul legislative  
pentru o perioada de 10 ani  
pentru a va proteja de  
modificari legislative ulterioare  
(sau puteti sa nu o faceti, daca noile  
prevederi sunt mai avantajoase)*



---

## POSSIBILITY OF TRANSFER OF EARNED INCOME OUTSIDE THE REPUBLIC OF MOLDOVA

*Posibilitatea transferului  
profitului obtinut peste hotarele  
Republicii Moldova*









# THANK YOU FOR REQUESTING A QUOTATION:

**"CAAN" Industrial Park and Free  
Economic Zone  
1 V. Crasescu street,  
MD-3701, Straseni city, Republic of Moldova  
Tel/Fax +373 237 22319  
GSM: +373 69 588 111  
info@caan.md  
office@caan.md  
c.chitanu@caan.md  
www.caan.md**